



CAMERE / BEDROOMS

FACILE 2.0



MADE IN ITALY

CATALOGO CATALOGUE

Facile 2.0	2
Nuovi gruppi New sets	8
Camere Bedrooms	10
Camere a ponte Bridge bedrooms	44

DATI TECNICI TECHNICAL

Finiture Finishes	54
Caratteristiche tecniche armadi battenti Hinged doors wardrobes technical features	56
Caratteristiche tecniche armadi scorrevoli Sliding doors wardrobes technical features	64
Caratteristiche tecniche gruppi Bedroom sets technical features	70
Caratteristiche tecniche letti Beds technical features	78

PRICE LIST

Listino Price list	86
Composizioni a catalogo Catalogue compositions	124

FACILE 2.0

Comporre nuovi spazi, non è mai stato così Facile!

Questo progetto è pensato e realizzato per creare ambienti personalizzati e su misura per te.

Ridisegniamo la zona notte, facilitando le tue abitudini e dando forma ai tuoi desideri.

Una vasta gamma di proposte che combinano moduli, finiture ed elementi, puntando su estetica, funzionalità e ottimo rapporto qualità prezzo.

With Facile, creating new spaces has never been so easy!

This project is conceived and produced to create rooms tailored to your personality and needs.

We redesign your bedroom to respond to your habits and let your wishes take shape.

A vast range that combines modules, finishes and elements, offering style, convenience and excellent value for money.



Finiture

Cinque nuove finiture si aggiungono per arricchire la gamma di nuance del programma: Noce biondo, Metallo oro, Metallo argento, Bianco altea, Bianco.

Finishes

Five new finishes are added to expand the programme's colour assortment: Noce biondo, Metallo oro, Metallo argento, Bianco altea, Bianco.



Maniglia

M2: Geometria e versatilità, sono le caratteristiche della nuova maniglia che unisce estetica e funzionalità.

M2 Handle

Geometrical and versatile, the new handle is both attractive and functional.

Pomolo

Il pomolo, dona una maggiore ergonomia ed eleganza alle ante in vetro.

Knob

The knob enhances both the elegance and the convenience of glass doors.

**Thai**

Composto di comò, comodino e settimino, il gruppo è disponibile con maniglia dedicata, vano a giorno e piano a vista.

Thai

Comprising chest of drawers, bedside table and tallboy, the set is available with special handle, open section and shelf.

**Duo**

Nuove finiture e maniglie, per arredare la tua zona notte ottimizzando i volumi di contenimento.

Duo

New finishes and handles to furnish your bedroom with style and optimise storage spaces.

**Nuovo ponte con moduli laterali da 90**

Dal design lineare, elementi discreti e pratici per mantenere tutto in ordine. Pensato in linea allo stile semplice della collezione.

New over head composition with 90 cm side modules.

Simply styled, with tasteful, practical elements to keep everything neat and tidy. Designed to blend into the collection's unfussy style.



Elemento scrivania

Eleganza e funzionalità: un elemento versatile, per goderti tutto il comfort su misura per te.

Desk element

Elegant and functional: a versatile element, so you can enjoy comfort tailored to your preferences.



Portavaligia

Una soluzione per le tue esigenze, e per sfruttare al meglio lo spazio. Nella camera ideale, i tuoi progetti vengono al primo posto.

Luggage stand

A solution for your needs, to make optimal use of space. In the ideal bedroom, your ideas come first.



Nuovi letti

Letti moderni arredano la zona notte e ci accolgono in un morbido abbraccio nei momenti di relax. Nelle proposte imbottite il rivestimento garantisce una comodità senza uguali, in un'atmosfera chic ed ovattata. Pratiche ed essenziali, le proposte con struttura in legno, introducono un nuovo concetto di modernità ed essenzialità molto contemporaneo.

New beds

New, modern beds add style to the bedroom and envelop us in a soft embrace when it's time to relax. In the padded bedheads, the upholstery provides unrivalled comfort - chic and soft. Practical and elegant, the wooden frame beds offer a new, very contemporary concept of modernity and simplicity.



Nuovi gruppi / New sets



Duo

Il programma Facile presenta due new entries nella proposta notte: nuove finiture, nuovo design e nuove maniglie. Thai e Duo rappresentano un'importante innovazione, arricchiscono la gamma di prodotti, introducendo un nuovo concetto di modernità.

The Facile programme offers two bedroom new entries: new finishes, new design and new handles. Thai and Duo are strongly innovative, enhancing the product range and introducing a new concept of modernity.



Thai



Cady



Small



Lux



Aux

Con una gamma di finiture nuova ed arricchita e la proposta di nuove maniglie, i gruppi del programma Facile si vestono di nuovo. All'interno delle proposte troverete il gruppo Cady, Small, Lux e Aux, abbinati agli armadi e i letti della proposta notte, studiati per aiutarvi a realizzare il vostro personalissimo progetto di casa.

With a new, wider range of finishes and new handles, the Facile programme sets acquire a new look. The offering includes the Cady, Small, Lux and Aux set, styled to match the wardrobes and beds in the bedroom assortment, designed to enable you to create your very own home furnishing project.



CAMERE
BEDROOMS

VFB005

Gruppo Aux / Aux Set: Bianco
Armadio / Wardrobe: Olmo natura / Bianco
Letto Reflex / Reflex bed: Olmo natura





VFB003

Gruppo Cady / Cady Set: Noce biondo / Metallo oro

Armadio / Wardrobe: Noce biondo / Metallo oro

Letto Era / Era bed: Tessuto nabuk cetra beige

VFB002

Gruppo Small / Small Set: Bianco altea / Metallo argento

Armadio / Wardrobe: Bianco altea

Letto Slim / Slim bed: Bianco altea / Metallo argento





VFB016

Gruppo Thai / Thai Set: Bianco altea / Metallo argento

Armadio / Wardrobe: Bianco altea / Metallo argento

Letto Reflex / Reflex bed: Bianco altea

VF8015

Gruppo Thai / Thai Set: Olmo natura / Metallo oro

Armadio / Wardrobe: Olmo natura / Metallo oro

Letto Misam / Misam bed: Ecopelle lila tortora



VFB014

Gruppo Lux / Lux Set: Orzo

Armadio / Wardrobe: Orzo

Letto Dione / Dione bed: Tessuto nabuk cetrà antracite





VFB013

Gruppo Cady / Cady Set: Noce biondo / Bianco lucido

Armadio / Wardrobe: Noce biondo / Bianco lucido

Letto Atik / Atik bed: Ecopelle lira bianco



VFB009

Gruppo Duo / Duo Set: Bianco altea / Metallo argento
Armadio / Wardrobe: Bianco altea / Metallo argento
Letto Vulcano / Vulcano bed: Bianco altea

VFB012

Gruppo Duo / Duo Set: Noce biondo / Metallo oro

Armadio / Wardrobe: Noce biondo / Metallo oro

Letto Slim / Slim bed: Noce biondo / Metallo oro





VFB011

Gruppo Aux / Aux Set: Bianco altea
Armadio / Wardrobe: Bianco altea / Bianco lucido
Letto Vulcano / Vulcano bed: Bianco altea

VFB001

Gruppo Aux / Aux Set: Orzo

Armadio / Wardrobe: Noce biondo

Letto Metiz / Metiz bed: Noce biondo / Orzo





VFB006

Gruppo Duo / Duo Set: Noce biondo / Metallo argento

Armadio / Wardrobe: Noce biondo / Metallo argento

Letto Reflex / Reflex bed: Noce biondo



VFB010

Gruppo Small / Small Set: Bianco alta
Armadio / Wardrobe: Bianco alta
Letto Metz / Metz bed: Bianco alta

VFB004

Gruppo Small / Small Set: Olmo natura

Armadio / Wardrobe: Olmo natura

Letto Metz / Metz bed: Olmo natura



VFB007

Gruppo Thai / Thai Set: Noce biondo / Orzo
Armadio / Wardrobe: Noce biondo
Letto Metz / Metz bed: Noce biondo / Orzo
Scrivania frigo / Scrivania frigo: Noce biondo
Portavaligie / Portavaligie: Noce biondo



VF8003

Gruppo Small / Small Set: Olmo natura / Metallo argento
Armadio / Wardrobe: Olmo Natura / Metallo Argento
Letto Resort / Resort bed: Olmo natura / Metallo argento
Scrivania frigo / Scrivania frigo: Olmo natura / Metallo argento
Portavaligie / Portavaligie: Olmo natura





CAMERE A PONTE
BRIDGE BEDROOMS

VFB07

Armadio a ponte / Bridge wardrobe: Bianco altea/ Bianco lucido/ Metallo argento

Letto Reflex / Reflex bed: Bianco altea

Comò Aux / Comò Aux: Bianco lucido



VF8018

Armadio / Wardrobe: Olmo natura / Metallo oro

Armadio a ponte / Bridge wardrobe: Olmo natura / Metallo oro

Letto Vulcano / Vulcano bed: Olmo natura



VFB019

Armadio / Wardrobe: Noce biondo / Metallo argento

Armadio a ponte / Bridge wardrobe: Noce biondo / Metallo argento

Letto Vulcano / Vulcano bed: Noce biondo



TECHNICALS



Imab Group S.p.A.
Via L. Falasconi, 92
61033 Fermignano (PU) - ITALY
tel. +39 0722 335 701
www.imab.com

TECHNICALS

FINITURE FINISHES

(NO) NOBILITATI / MELAMINE FINISHES

ESSENZE / WOOD FINISHES

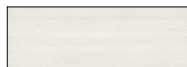

Bianco altea



Olmo natura



Noce biondo

COLORATI / COLOURED FINISHES



Bianco nobilitato



Orzo

EFFETTO METALLO / METAL EFFECT



Oro

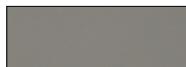

Argento

(LC) LACCATI / LACQUERED FINISHES

LACCATI LUCIDI / GLOSSY LACQUERED FINISHES



Bianca lucido

(CA) ECOPELLE CALI / CALI ECOLEATHER

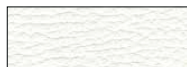

Bianco

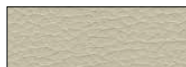

Fango

(LR) ECOPELLE LIRA / LIRA ECOLEATHER



Bianco

*Rif. Ecopelle Cali Bianco (H0)



Tortora

*Rif. Pelle Royal Marrone (O3)

* I tessuti di riferimento non hanno valore contrattuale e sono puramente indicativi. Rispettano la cromia ma non la trama.
The reference fabrics haven't contract value and are purely indicative. They respect the colors but not the texture.

(CT) NABUK CETRA / CETRA NABUK



Beige

*Rif. Tessuto Apollo Beige (P0)

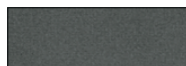

Antracite

*Rif. Tessuto Apollo Antracite (P6)

* I tessuti di riferimento non hanno valore contrattuale e sono puramente indicativi. Rispettano la cromia ma non la trama.
The reference fabrics haven't contract value and are purely indicative. They respect the colors but not the texture.

FINITURA INTERNA / INTERNAL FINISH



Tessuto glamour

TIPOLOGIE DI SPECCHIO / MIRROR TYPES



Specchio neutro

Alcuni elementi possono avere una diversa finitura interna a seconda della finitura esterna.
Consultare la tabella sottostante per le varie combinazioni.
Some units may have different internal finish according to its external finish. Check the combinations in the table below.

	Esterno in Essenza o Nobilitati Colorati	Esterno Laccato	Esterno Specchio
Ante Doors	Interno stesso colore Same colour	Interno Bianco nobilitato Internal side in Bianco nobilitato	Interno Tessuto Glamour Internal side in Tessuto Glamour
Fianchi Sides	Interno stesso colore Same colour	Interno Bianco nobilitato Internal side in Bianco nobilitato	-

Base, Cappello e Ripiani Base, Top and Shelves	Sempre in Tessuto Glamour / Always Tessuto Glamour		
Tramezzi Internal sides	Sempre in Tessuto Glamour / Always Tessuto Glamour		
Schiene Back panels	Sempre in Tessuto Glamour / Always Tessuto Glamour		

CARATTERISTICHE TECNICHE ARMADI BATTENTI

HINGED DOORS WARDROBES TECHNICAL FEATURES

MATERIALI E PANNELLI / MATERIALS AND PANELS

Per informazioni su materiali e pannelli, consultare la scheda prodotto in fondo al listino.
For information about materials and panels, check the product sheet in the last pages of this document.

FIANCHI E TRAMEZZI / SIDES

Tutti i fianchi e tramezzi sono realizzati in pannelli di particelle di legno classe E1 di spessore 18mm e sono predisposti di forature per fissaggio ferramenta (fori 1x1). I fianchi in finitura nobilitata colorato ed essenza sono dello stesso colore anche nel lato interno. I fianchi laccati sono laccati nel lato esterno e nobilitati dello stesso colore nel lato interno.

Each side or internal side is realized with E1 class wooden panels, thickness 18mm. Sides in melamine and wood finishes have the same finish in the inner side. The lacquered sides have melamine finish (same colour but not lacquered) in the inner side.

ANTE / DOORS

Tutte le ante sono realizzate in pannelli di particelle di legno classe E1 di spessore 18mm. Se l'anta è in finitura laccata, l'interno sarà in nobilitato dello stesso colore del frontale. Se è in essenza, anche il lato interno è in finitura essenza. L'interno dell'anta a specchio è in finitura Tessuto. Il bordo anta è sempre opaco, anche con finitura lucida. Le ante sono preforate internamente per il montaggio di tutti i modelli di maniglia.

Each door is realized with E1 class wooden panels, thickness 18mm. If the door is made in a lacquered colour, the internal side will be in melamine finish of the same colour of the frontal. If the door is in essence finish, the internal side will be in essence finish too. The internal side of the mirror doors are in Tessuto. Even with glossy finish, the edges are always in matt finish.

DOTAZIONE INTERNA STANDARD / STANDARD EQUIPMENT

Tutti gli armadi vengono forniti con ripiani interni spessore 25mm e tubi appendiabiti a sezione ovale in alluminio. Finitura interna: Tessuto Glamour.
Each wardrobe is provided with 25mm thick shelves and oval hanger tubes. Internal finish: Tessuto Glamour.

Moduli lineari

1 ripiano e 2 tubi
Linear units
1 shelf and 2 tubes

Elementi ponte

1 tubo per vano
Bridge units
1 tube for each unit

Terminali

5 ripiani (H.245)
4 ripiani (H.225)
End units
5 shelves (H.245)
4 shelves (H.225)

Angoli

1 ripiano e 2 tubi
Corner units
1 shelf and 2 tubes

Cabine

1 ripiano e 2 tubi
Clothes closet units
1 shelf and 2 tubes

INFORMAZIONI TECNICHE / TECHNICAL INFORMATION

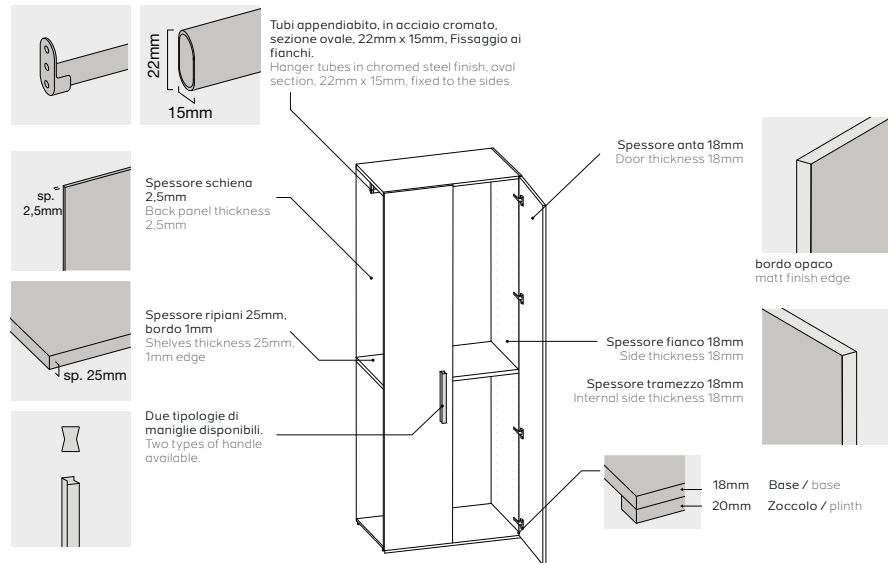

SPAZIO PER MONTAGGIO IN NICCHIA / MINIMUM GAP FROM CEILING

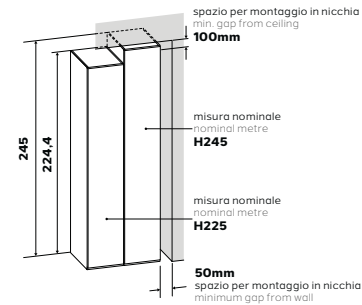

FORATURA FIANCHI E POSIZIONAMENTO / SIDES' HOLES AND POSITIONING

Nei moduli con anta H.245 e H.225 è possibile posizionare il ripiano ogni 6,4cm, ma è consigliabile assemblare il vano con posizione ripiano di serie come indicato nelle figure **A** e **B** (verificare dotazione interna).

You can put the shelves every 6.4cm but it's recommended to put them as shown in the pictures **A** and **B**.

H245

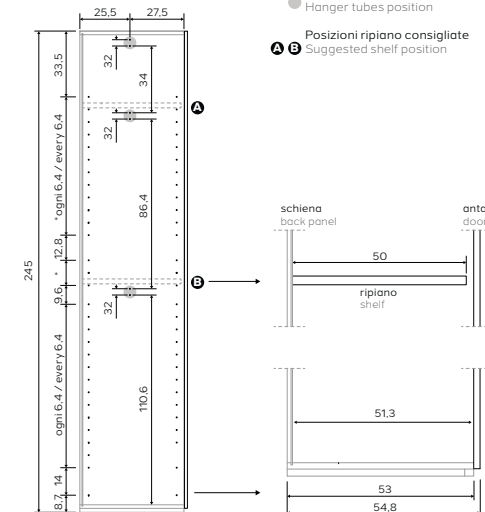

H225

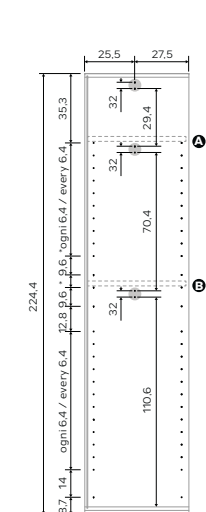

INGOMBRI MODULI UNITS MEASURES

ARMADI LINEARI / LINEAR WARDROBES

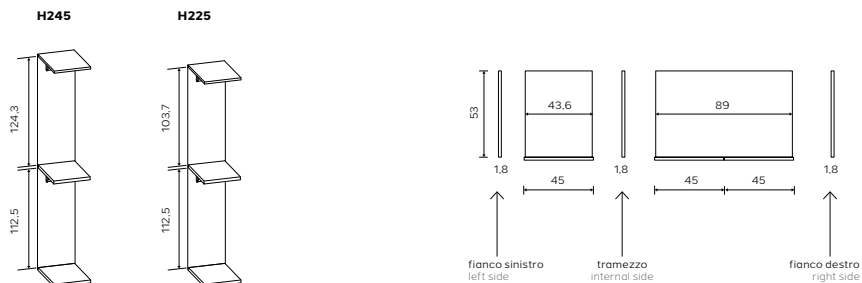

CABINA / CLOTHES CLOSET UNIT

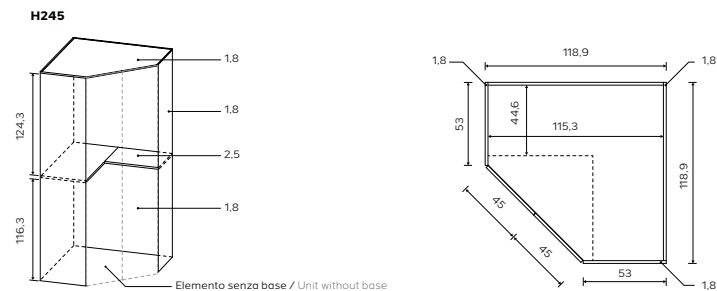

TERMINALE / END UNIT

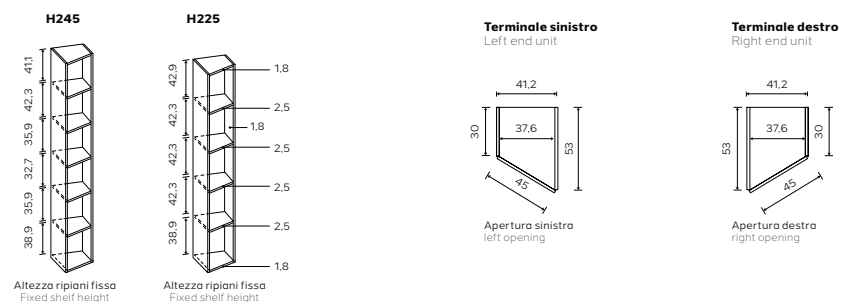

LIBRERIA L35 / L35 BOOKCASE UNIT

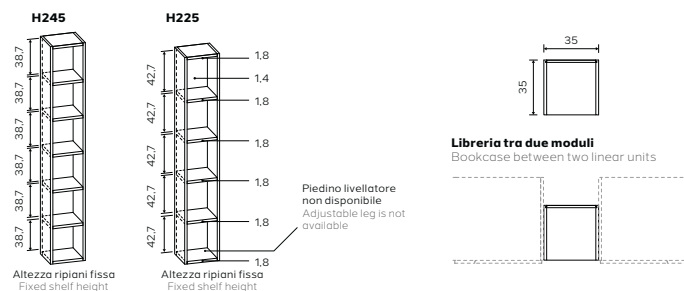

ANGOLO / CORNER UNIT

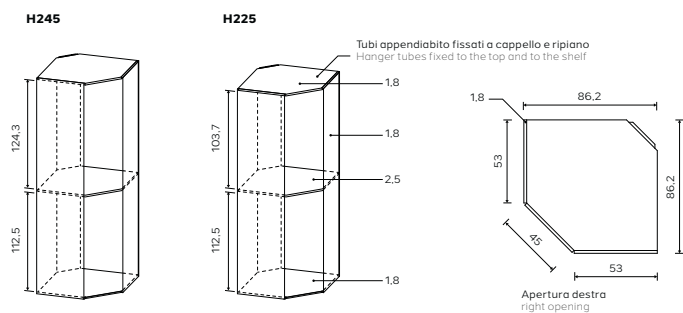

PONTE / BRIDGE UNIT

Ante ponte-senza maniglia / Bridge unit's doors without handles

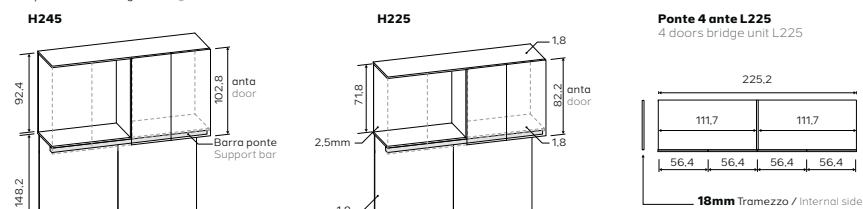

ACCESSORI PONTE BRIDGE UNIT ACCESSORIES

LIBRERIE PONTE / BOOKCASES FOR BRIDGE UNIT

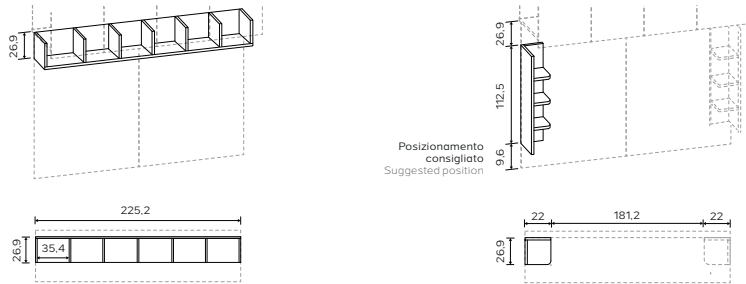

MENSOLA SOTTOPONTE / SHELF FOR BRIDGE UNIT

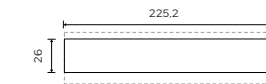
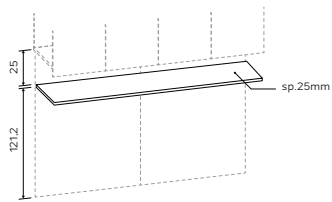

NB: posizionamento fisso con predisposizione, montaggio con viti da dietro il pannello.
Note: fixed positioning, assembling with screws from behind the bridge unit panel.

BOISERIE CON PORTAVALIGIA E SPECCHIO APPLICATO BOISERIE WITH LUGGAGE RACK AND MIRROR

BOISERIE CON PORTAVALIGIA E SPECCHIO APPLICATO / BOISERIE WITH LUGGAGE RACK AND MIRROR

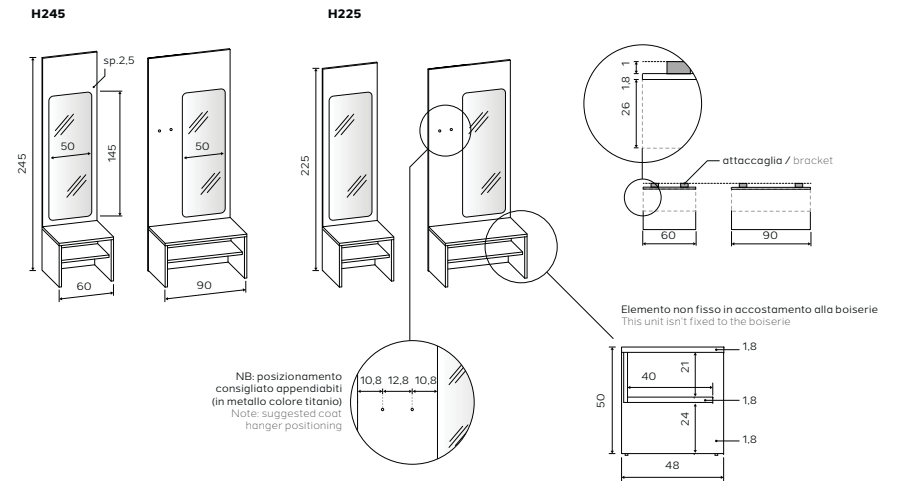

MONTAGGIO / ASSEMBLY

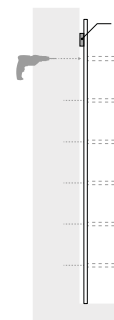

I pannelli boiserie sono dotati di fori sul lato posteriore per fissaggio attaccaglie e mensole da forare per inserimento reggimensola interno. La posizione delle mensole è fissa (vedi disegni tecnici nella pagina precedente).

There are prearranged holes on the back side of the boiserie. The holes must be pierced to apply the brackets and the internal supports. The position of the shelves is fixed (check the schemes in the previous page)

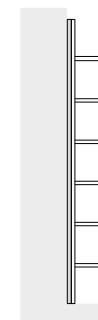

Il pannello boiserie è rifinito con un profilo adesivo da applicare sul retro per coprire le attaccaglie di fissaggio.

The boiserie is equipped with a double-sided tape that must be applied in the back side to cover the brackets.

MANIGLIE PER ARMADI HANDLES FOR WARDROBES

MANIGLIA M1 / HANDLE M1

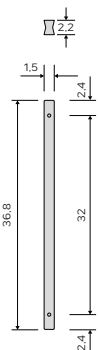

Maniglia L37 in MDF rivestito.
Finiture essenza o bianco lucido.
Passo 320mm

L37 MDF covered handle.
Wooden finishes and bianco lucido.
Hole pitch 320mm

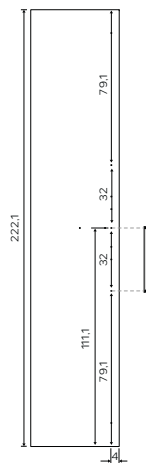
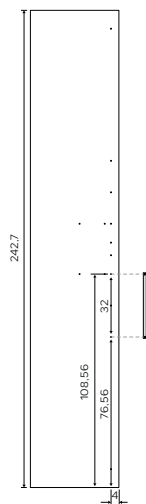

POMOLO PER ANTA SPECCHIO / KNOB FOR MIRROR DOOR



Pomolo in acciaio finitura titanio.
Passo: foro singolo.

Steel knob in titanium colour.
Hole pitch: single hole.

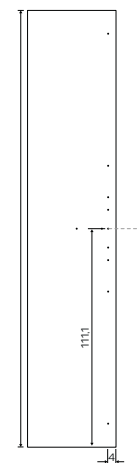
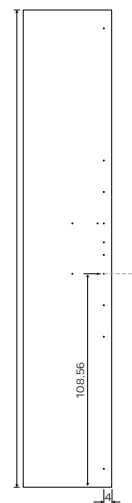

MANIGLIA M2 / HANDLE M2

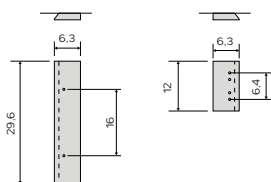

Maniglia L12 e L30 in MDF rivestito.
Finiture essenza o bianco lucido.
Passo: 160mm (maniglia lunga)
64mm (maniglia corta)

NB: su anta singola, solo maniglia L30

L12 and L30 MDF covered handle.
Wooden finishes and bianco lucido.
Hole pitch: 160mm (long handle)
64mm (short handle)

Note: single door wardrobe equipped with a single L30 handle.

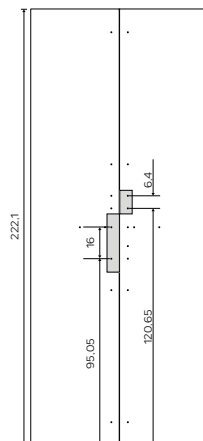
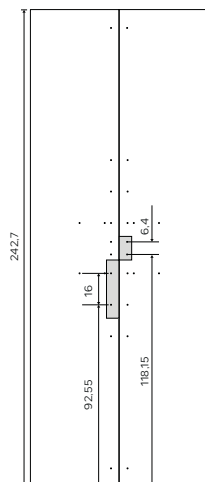

CARATTERISTICHE TECNICHE ARMADI SCORREVOLI

SLIDING DOORS WARDROBES TECHNICAL FEATURES

MATERIALI E PANNELLI / MATERIALS AND PANELS

Per informazioni su materiali e pannelli, consultare la scheda prodotto in fondo al listino.
For information about materials and panels, check the product sheet in the last pages of this document.

FIANCHI E TRAMEZZI / SIDES

Fianchi e tramezzi: tutti i fianchi e tramezzi sono realizzati in pannelli di particelle di legno classe E1. Fianchi sp.25mm, tramezzi sp.18mm, tramezzo speciale per armadio scorrevole 4 ante sp.25mm. Sono predisposti di forature per fissaggio ferramenta (fori 1x1). I fianchi in finitura nobilitata colorato ed essenza sono dello stesso colore anche nel lato interno. I fianchi laccati sono laccati nel lato esterno e nobilitati dello stesso colore nel lato interno.

Each side or internal side is realized with E1 class wooden panels. Thickness: 25mm sides, 18mm internal sides, 25mm special internal side for 4 sliding doors wardrobe. Sides in melamine and wood finishes have the same finish in the inner side. The lacquered sides have melamine finish (same colour but not lacquered) in the inner side.

ANTE / DOORS

Le ante sono realizzate in pannelli di particelle di legno classe E1 di spessore 18mm.

Se l'anta è in finitura laccata lucida, l'interno sarà in nobilitato dello stesso colore del frontale. Se è in essenza, anche il lato interno è in finitura essenza. L'interno dell'anta a specchio è in finitura Tessuto.

The doors are realized with E1 class wooden panels, thickness 18mm. If the door is made in a lacquered colour, the internal side will be in melamine finish of the same colour of the frontal. If the door is in essence finish, the internal side will be in essence finish too. The internal side of the mirror doors are in Tessuto.

DOTAZIONE INTERNA STANDARD / STANDARD EQUIPMENT

Dotazione interna: tutti gli armadi vengono forniti con ripiani interni e fianchi spessore 25mm e tubi appendiabiti a sezione ovale in alluminio. Ogni vano è dotato di un ripiano centrale e 2 tubi appendiabiti.

Standard equipment: each wardrobe is provided with 25mm thick central shelves and 2 oval hanger tubes. Internal finish: Tessuto Glamour.

INFORMAZIONI TECNICHE / TECHNICAL INFORMATION

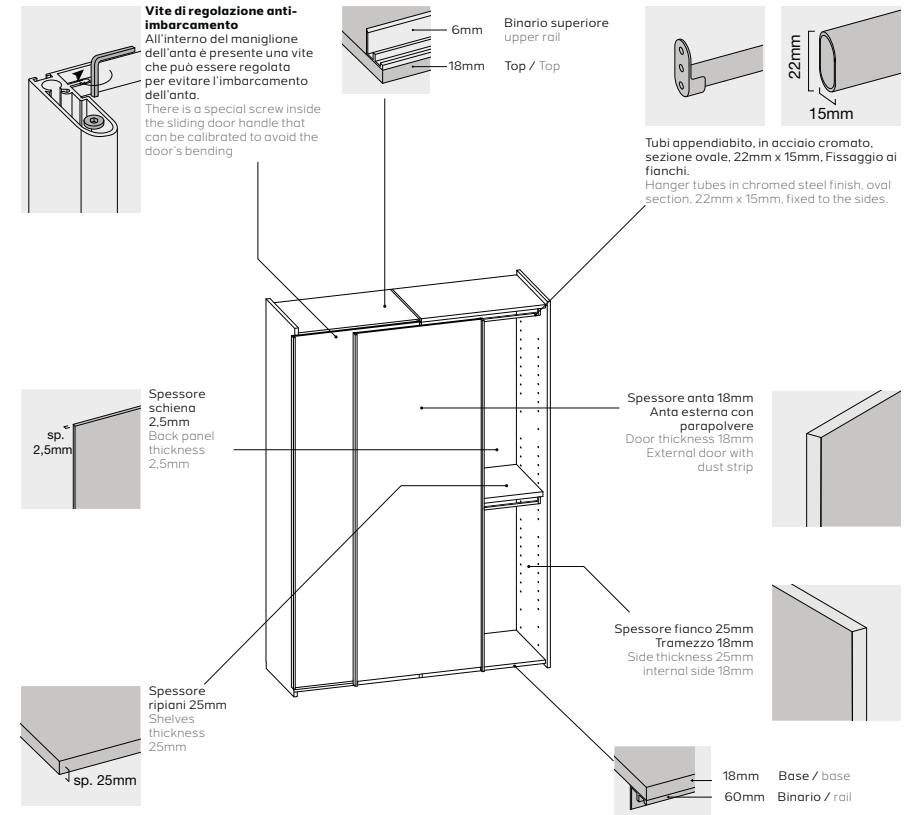

CARATTERISTICHE TECNICHE ARMADI SCORREVOLI

SLIDING DOORS WARDROBES TECHNICAL FEATURES

ALTEZZE / HEIGHTS

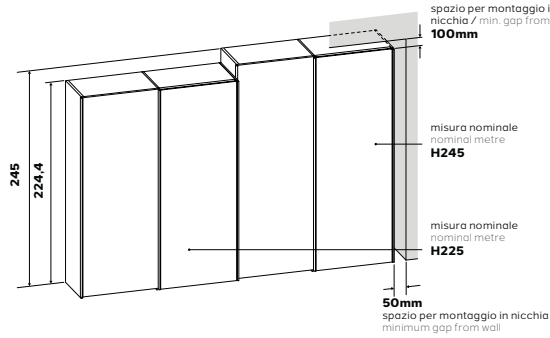

PROFONDITÀ / DEPTHS

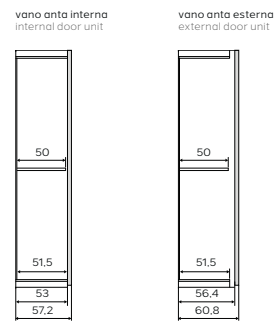

INGOMBRI INTERNI / INTERNAL MEASURES

H245

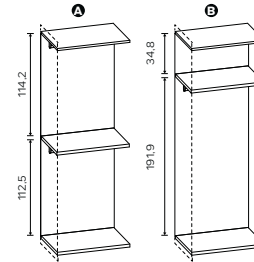

H225

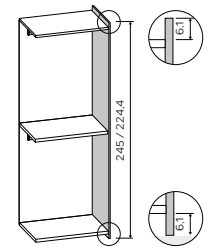
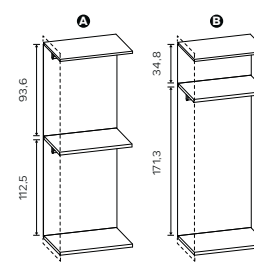

LARGHEZZE ARMADI L90

L90 UNITS WIDTHS

2 Ante L90
2 L90 Doors

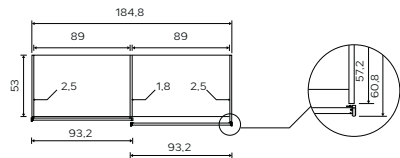

3 Ante L90
3 L90 Doors

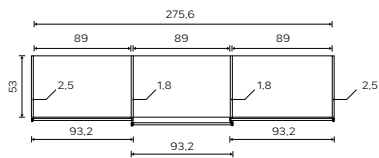

4 Ante L90
4 L90 Doors

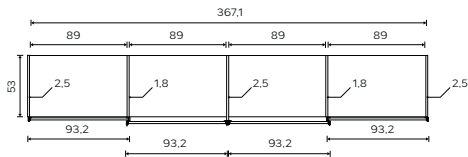

LARGHEZZE ARMADI L120-135

L120-135 UNITS WIDTHS

2 Ante L120
2 L120 Doors

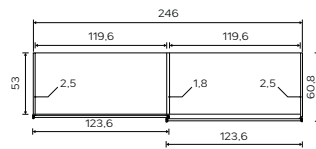

2 Ante L135
2 L135 Doors

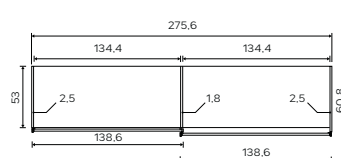

Nei moduli con anta H.245 e H.225 è possibile posizionare il ripiano ogni 6.4cm, ma è consigliabile assemblare il vano con posizione ripiano di serie come indicato nelle figure A e B (verificare dotazione interna).
You can put the shelves every 6.4cm but it's recommended to put them as shown in the pictures A and B

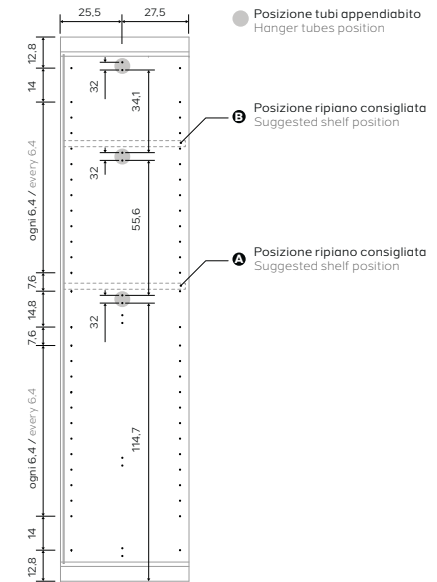
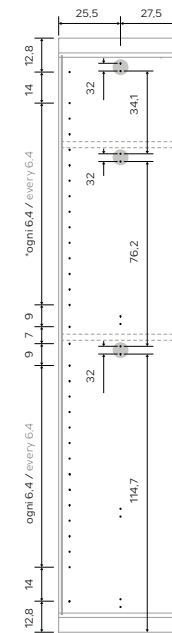

● Posizione tubi appendiabito
Hanger tubes position

● Posizione ripiano consigliata
Suggested shelf position

● Posizione ripiano consigliata
Suggested shelf position

FIANCHI E MANIGLIONI SIDES AND HANDLES

MANIGLIONI ANTA INTERNA INTERNAL DOOR'S HANDLE

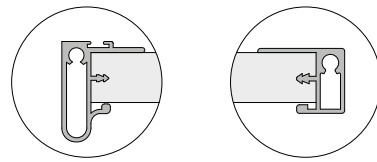
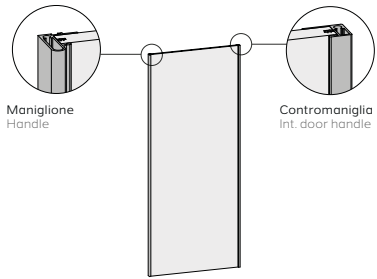

Esempio su armadio / Wardrobe examples

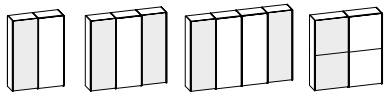

MANIGLIONI ANTA ESTERNA EXTERNAL DOOR'S HANDLE

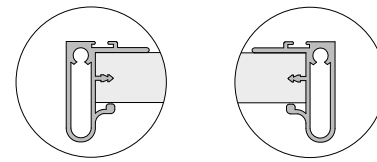
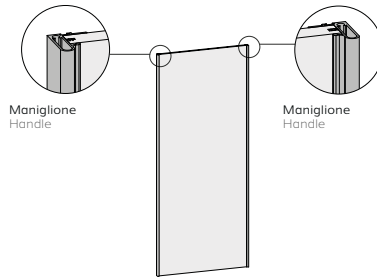

Esempio su armadio / Wardrobe examples

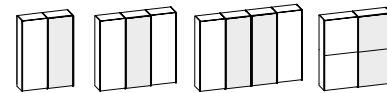

BINARI RAILS

Gli armadi 2 ante scorrevoli sono predisposti di default per il montaggio con fianco P53 a sinistra e fianco P56.4 a destra e di conseguenza anta interna a sinistra e anta esterna a destra. Se per esigenze particolari si ha la necessità di invertire le ante, è possibile farlo montando il fianco P56.4 a sinistra e il P53 a destra. Va poi modificata anche l'installazione del binario superiore come da schema sotto.

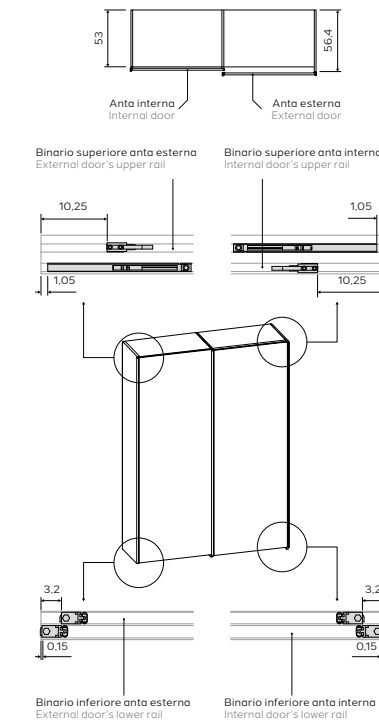

2 sliding doors wardrobes are assembled by default with P53 side to the left and P56.4 side to the right. As a result, the wardrobe will have the internal door on the left side and the external door on the right side. It's possible to invert this arrangement by reversing the sides and putting the P56.4 side to the left and the P53 side to the right. The upper rails must be installed as described below.

MONTAGGIO STANDARD STANDARD ASSEMBLING

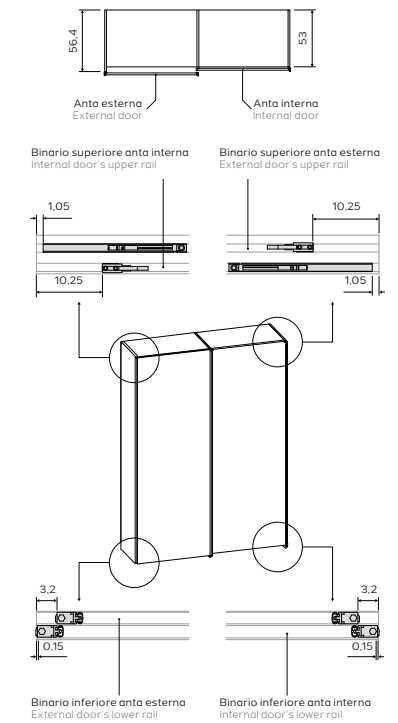

MONTAGGIO INVERTITO INVERTED ASSEMBLING

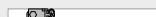

-  Finecorsa a pinza in apertura / pincer-shaped limit for opening
-  Fermo superiore ammortizzato in chiusura / upper stop with soft closing
-  Fermo per binario inferiore in apertura e chiusura / lower stop for opening and closing

CARATTERISTICHE TECNICHE GRUPPI

BEDROOM SETS TECHNICAL FEATURES

CADY

Con maniglia M1 / With M1 handle
Maniglia L18,3/23,4 in MDF rivestito, essenza o bianco lucido.
 L18,3/23,4 handle in covered MDF. Wooden finishes and bianco lucido.

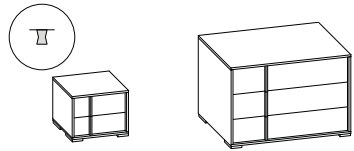

Informazioni tecniche / Technical information

- Prodotto fornito montato.
- Apertura con maniglia in MDF rivestito.
- Dotato di piedino fisso.
- In dotazione ferramenta antiribaltamento.
- Guide a rotella non ammortizzate con portata 30 kg.
- Disponibile kit ammortizzatore optional.
- Spessore cassa e frontali 18mm.
- Non si eseguono fuori misura.

Delivered assembled.
 Opening with covered MDF handle.
 Equipped with fixed legs.
 Equipped with antitip hardware.
 Equipped with standard rails. Capacity: 30 kg.
 Optional soft closing rails.
 Structure and drawers thickness 18mm.
 Custom made elements aren't allowed.

Con maniglia M2 / With M2 handle
Maniglia L24,8/55 in MDF rivestito. Essenza o bianco lucido.
 L24,8/55 handle in covered MDF. Wooden finishes and bianco lucido.

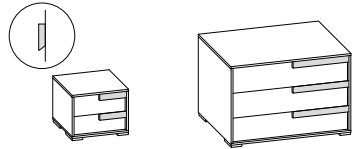

Misure / Measures

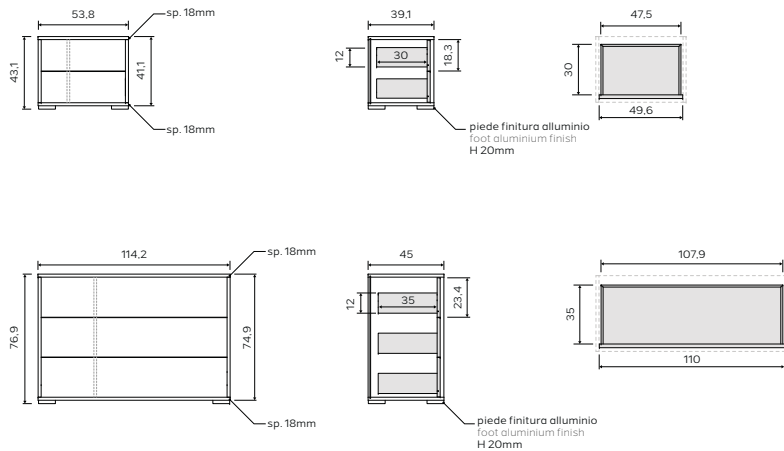

SMALL

Con maniglia M1 / With M1 handle
Maniglia L18,2 in MDF rivestito, essenza o bianco lucido.
 L18,2 handle in covered MDF. Wooden finishes and bianco lucido.

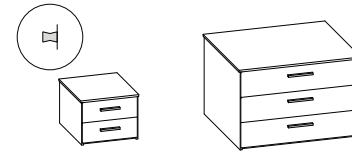

Informazioni tecniche / Technical information

- Prodotto fornito montato.
- Apertura con maniglia in MDF rivestito.
- Dotato di piedino fisso.
- In dotazione ferramenta antiribaltamento.
- Guide a rotella non ammortizzate con portata 30 kg.
- Disponibile kit ammortizzatore optional.
- Spessore cassa e frontali 18mm.
- Non si eseguono fuori misura.

Delivered assembled.
 Opening with covered MDF handle.
 Equipped with fixed legs.
 Equipped with antitip hardware.
 Equipped with standard rails. Capacity: 30 kg.
 Optional soft closing rails.
 Structure and drawers thickness 18mm.
 Custom made elements aren't allowed.

Con maniglia M2 / With M2 handle
Maniglia L12/24,8 in MDF rivestito. Essenza o bianco lucido.
 L12/24,8 handle in covered MDF. Wooden finishes and bianco lucido.

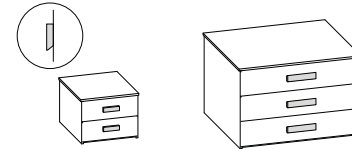

Misure / Measures

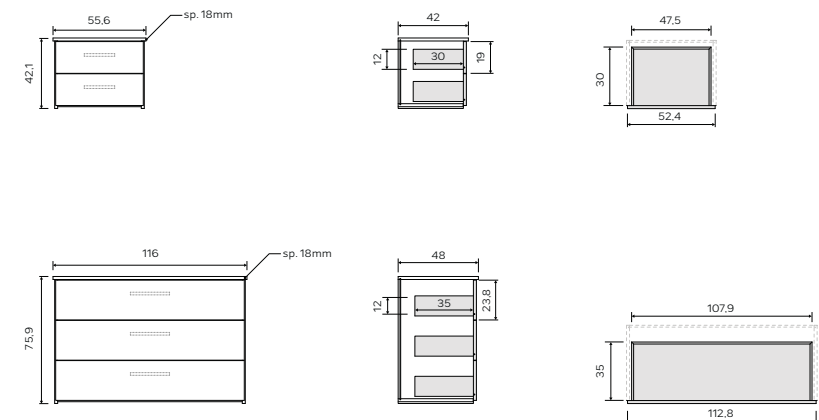

CARATTERISTICHE TECNICHE GRUPPI

BEDROOM SETS TECHNICAL FEATURES

AUX

Senza maniglia / Without handle



Informazioni tecniche / Technical information

- Prodotto fornito montato.
- Non sono previsti mix di finiture cassa e frontale.
- Apertura a presa laterale.
- Dotato di piedino fisso.
- In dotazione ferramenta antiribaltamento.
- Guide a rotella non ammortizzate con portata 30 kg.
- Spessore cassa e frontali 18mm.
- Non si eseguono fuori misura.

- Delivered assembled.
- Structure and drawers finish mixes are not available.
- Lateral opening.
- Equipped with fixed legs.
- Equipped with antitip hardware.
- Equipped with standard rails. Capacity: 30 kg.
- Structure and drawers thickness 18mm.
- Custom made elements aren't allowed.

Misure / Measures

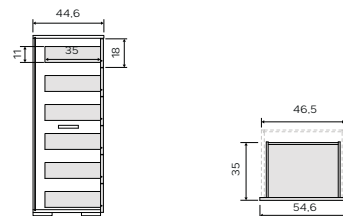
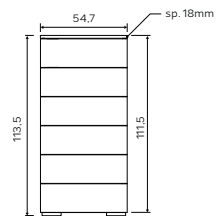
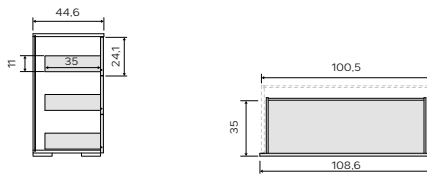
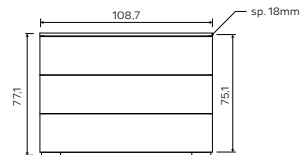
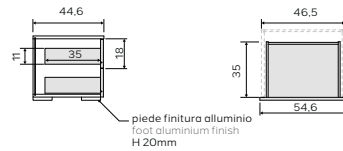
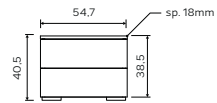

LUX

Con maniglia M1 / With M1 handle

Maniglia L8 in MDF rivestito. Essenza o bianco lucido.
L8 handle in covered MDF. Wooden finishes and bianco lucido.

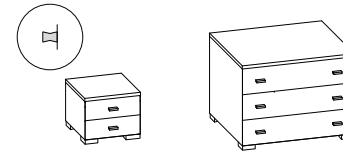

Informazioni tecniche / Technical information

- Prodotto fornito montato.
- Non sono previsti mix di finiture cassa e frontale.
- Apertura con maniglia in MDF rivestito.
- Dotato di piedino fisso.
- In dotazione ferramenta antiribaltamento.
- Guide a rotella non ammortizzate con portata 30 kg.
- Spessore cassa e frontali 18mm.
- Non si eseguono fuori misura.

- Delivered assembled.
- Structure and drawers finish mixes are not available.
- Opening with covered MDF handle.
- Equipped with fixed legs.
- Equipped with antitip hardware.
- Equipped with standard rails. Capacity: 30 kg.
- Structure and drawers thickness 18mm.
- Custom made elements aren't allowed.

Con maniglia M2 / With M2 handle

Maniglia L12 in MDF rivestito. Essenza o bianco lucido.
L12 handle in covered MDF. Wooden finishes and bianco lucido.

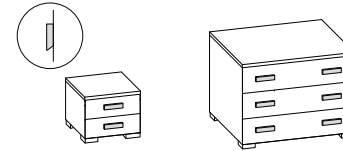

Misure / Measures

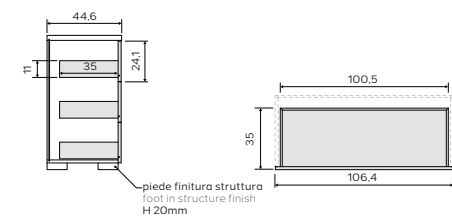
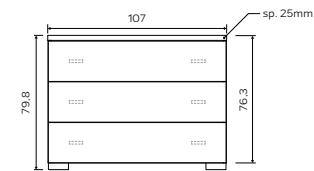
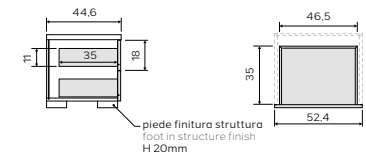
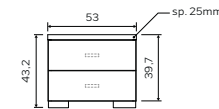

CARATTERISTICHE TECNICHE GRUPPI BEDROOM SETS TECHNICAL FEATURES

THAI con vano a giorno / with open unit

Con maniglia dedicata / With dedicated handle

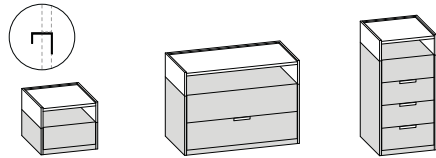

Informazioni tecniche / Technical information

Prodotto fornito montato.
Apertura con maniglia in metallo colore alluminio, presa superiore.
Dotato di piedino fisso.
In dotazione ferramenta antiribaltamento.
Guide a rotella non ammortizzate con portata 30 kg.
Disponibile kit ammortizzatore optional.
Spessore cassa e frontali 18mm.
Non si eseguono fuori misura.

Delivered assembled.
Opening with metal handle, aluminium finish.
Equipped with fixed legs.
Equipped with antitip hardware.
Equipped with standard rails. Capacity: 30 kg.
Optional soft closing rails.
Structure and drawers thickness 18mm.
Custom made elements aren't allowed.

DUO

Con maniglia dedicata / With dedicated handle

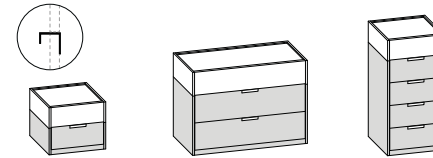

Informazioni tecniche / Technical information

Prodotto fornito montato.
Apertura con maniglia in metallo colore alluminio, presa superiore.
Dotato di piedino fisso.
In dotazione ferramenta antiribaltamento.
Guide a rotella non ammortizzate con portata 30 kg.
Disponibile kit ammortizzatore optional.
Spessore cassa e frontali 18mm.
Non si eseguono fuori misura.

Delivered assembled.
Opening with metal handle, aluminium finish.
Equipped with fixed legs.
Equipped with antitip hardware.
Equipped with standard rails. Capacity: 30 kg.
Optional soft closing rails.
Structure and drawers thickness 18mm.
Custom made elements aren't allowed.

Misure / Measures

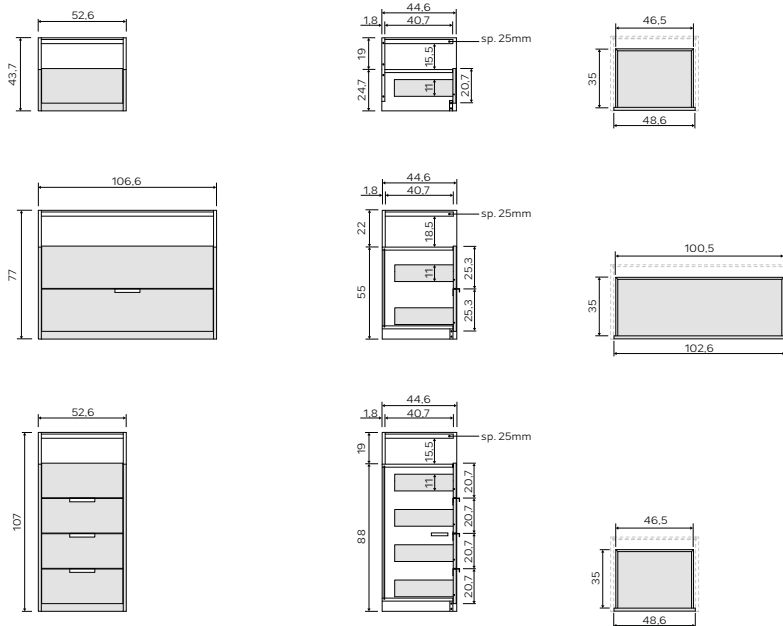

Misure / Measures

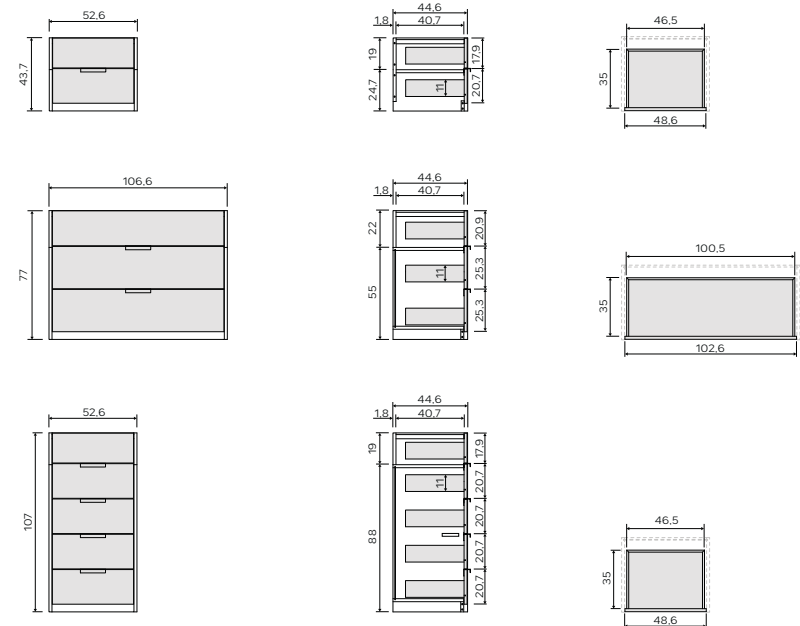

CARATTERISTICHE TECNICHE GRUPPI BEDROOM SETS TECHNICAL FEATURES

SCRIVANIA / DESK

Informazioni tecniche / Technical information

- Disponibile con base frigo sia destra che sinistra.
- Anta dotata di pomolo in metallo, finitura titanio.

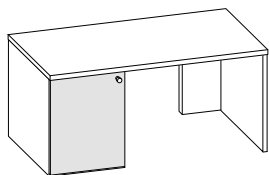

Available in both right and left version.
Door equipped with metal knob in titanium finish.

Misure / Measures

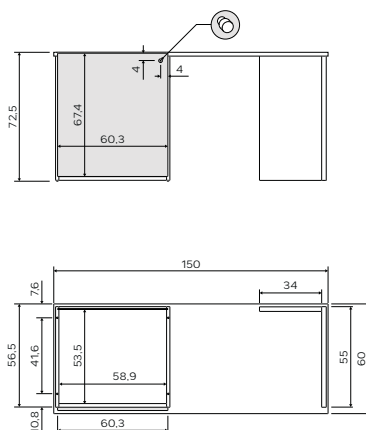

CARATTERISTICHE TECNICHE LETTI LEGNO WOODEN BEDS TECHNICAL FEATURES

CARATTERISTICHE GIROLETTO GEMINI / GEMINI BEDFRAME FEATURES

- A Fondi contenitore / Bottom panels for bed with box**
Fondi spessore 8mm in finitura Tessuto Grigio.
Bottom panels 8mm in Tessuto Grigio finishing.
- B Tipologia rete / Bedspring type**
Rete a doga unica.
Bedspring with unique slot.
- C Lati giroletto / Bedframe sides**
Giroletto 3 lati: i fascioni sono fissati alla testiera. Il giroletto per modello SLIM ha 4 lati.
Bedframe with 3 sides: the bedframe sides are fixed to the headboard. The bedframe for SLIM bed has 4 sides instead of 3.
- D Angolari / Supports type**
N.4 angolari divisi per supporto rete e unione giroletto e testiera.
N.4 splitted supports for bedspring and junction between headboard and bedframe.
- E Misure giroletto GEMINI / GEMINI bedframe's measures**

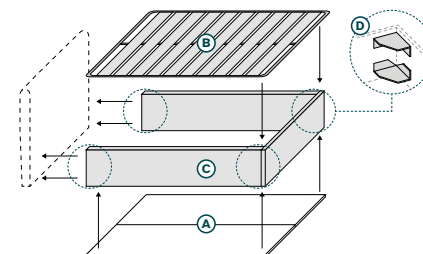

- F Piede P31 / P31 foot**



colore: alluminio / colour: aluminium

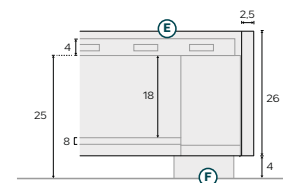

CARATTERISTICHE GIROLETTO GIGLIO / GIGLIO BEDFRAME FEATURES

- A Tipologia rete / Bedspring type**
Rete a doga unica.
Bedspring with unique slot.
- B Lati giroletto / Bedframe sides**
Giroletto 3 lati: i fascioni sono fissati alla testiera.
Bedframe with 3 sides: the bedframe sides are fixed to the headboard.
- C Angolari / Supports type**
N.4 angolari per supporto rete e unione giroletto e testiera.
N.4 supports for bedspring and junction between headboard and bedframe.
- E Misure giroletto GIGLIO / GIGLIO bedframe's measures**

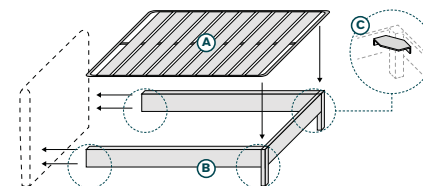

- F Piede P30 / P30 foot**



colore: come giroletto / colour: same colour of the bedframe

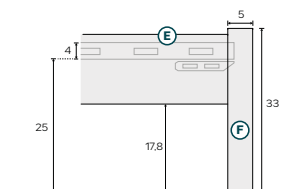

CARATTERISTICHE TECNICHE LETTI LEGNO

WOODEN BEDS TECHNICAL FEATURES

REFLEX

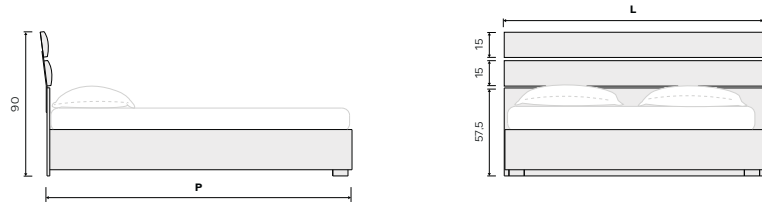

Gioiello GEMINI (3 lati) / GEMINI bedframe (3 sides)

Rete / Bedspring	L	P	Utile interno
160x190	169	205	162.5 x 193
160x200	169	215	162.5 x 203

METIZ

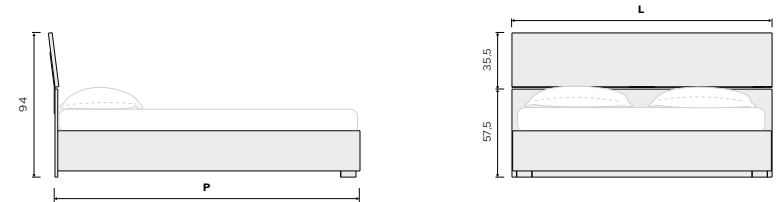

Gioiello GEMINI (3 lati) / GEMINI bedframe (3 sides)

Rete / Bedspring	L	P	Utile interno
160x190	169	202	162.5 x 193
160x200	169	212	162.5 x 203
180x200	189	212	182.5 x 203
150x190	159	202	152.5 x 193

Gioiello GIGLIO / GIGLIO bedframe

Rete / Bedspring	L	P	Utile interno
160x190	169	205	162.5 x 193

VULCANO

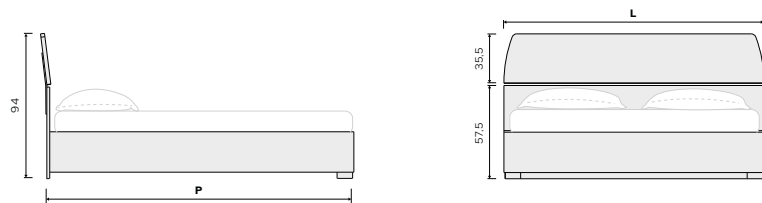

Gioiello GEMINI (3 lati) / GEMINI bedframe (3 sides)

Rete / Bedspring	L	P	Utile interno
160x190	169	205	162.5 x 193
160x200	169	215	162.5 x 203

SLIM

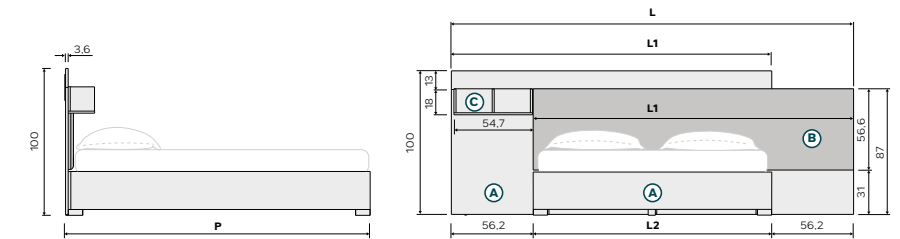

Gioiello GEMINI (4 lati) / GEMINI bedframe (4 sides)

Rete / Bedspring	L	L1	L2	P	Utile interno
160x190	280.2	223.2	167.6	200	162.5 x 193
160x200	280.2	223.2	167.6	210	162.5 x 203
180x200	300.2	243.2	187.6	210	182.5 x 203
150x190	270.2	213.2	157.6	200	152.5 x 193

- A** Letto Bed
- B** Pannello imbottito/legno: sempre posizionato a destra
Upholstered or wooden panel: always on the right side
- C** Libreria optional
Optional bookcase

LETTI IMBOTTITI CON GIROLETTO 3 LATI G25

UPHOLSTERED BEDS WITH G25 BEDFRAME

CARATTERISTICHE / FEATURES

A Fondi contenitore / Bottom panels for bed with box
Fondi spessore 8mm in finitura Tessuto Grigio.
Bottom panels 8mm in Tessuto Grigio finishing.

B Tipologia rete / Bedspring type
Rete a doga unica.
Bedspring with unique slot.

C Lati giroletto / Bedframe sides
Giroletto 3 lati: i fascioni sono fissati alla testiera. L'interno dei giroletti imbottiti è rivestito con vellurino grigio.
Bedframe with 3 sides, the bedframe sides are fixed to the headboard. The bedframe inner sides of upholstered bed frames are covered with a soft grey cloth.

D Angolari / Supports type
N.4 angolari per supporto rete e unione giroletto e testiera.
N.4 supports for bedspring and junction between headboard and bedframe.

E Misure giroletto G25 / G25 Bedframe's measures
Tutti i letti imbottiti della collezione Facile 2.0 hanno come giroletto il modello G25, le cui misure sono descritte qui.
The upholstered beds of this collection have G25 bedframe. Its measures are described here.

F Piede P42 / P42 foot



colore: nero / colour: black.

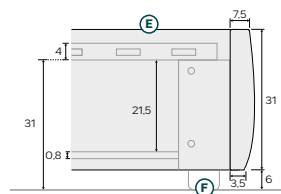
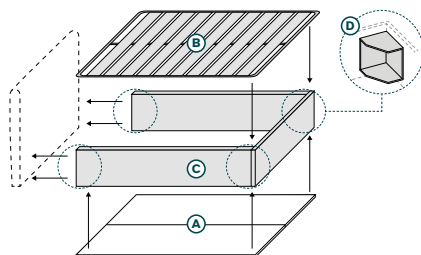

MISAM

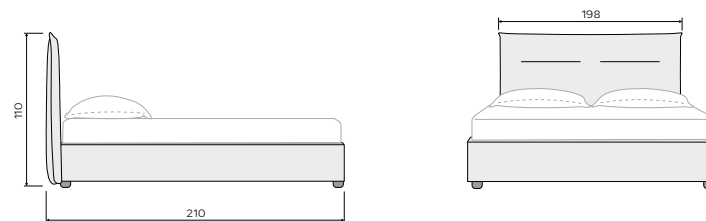

RIGEL

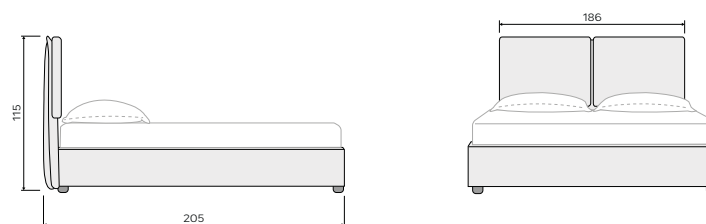

ATIK

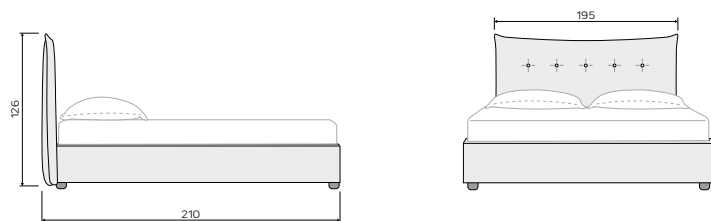

DIONE BASIC

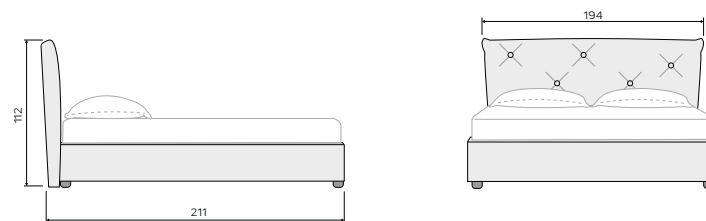

LETTI IMBOTTITI CON GIROLETTO 3 LATI G25
UPHOLSTERED BEDS WITH G25 BEDFRAME

ESEDRA BASIC

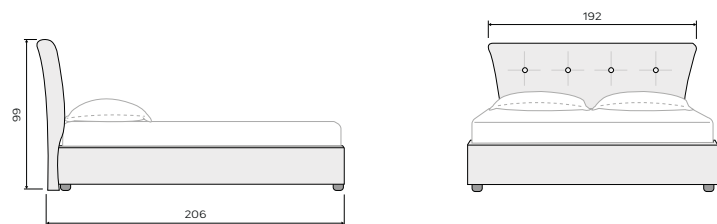

ERA BASIC

